

# Design Improvement

**FHDI00013**

(Juratek SCA100)

To Fit:

SCANIA: 4 series, G series, K series, L series, P series, R series, S Series

OE Ref:

SCANIA:1367735, 1386866, 1402272, 1852817, 1889543

## OEM Design

### Feature

Wall type vents provide poor support for the braking surface, which can result in high spots and thermal cracking.

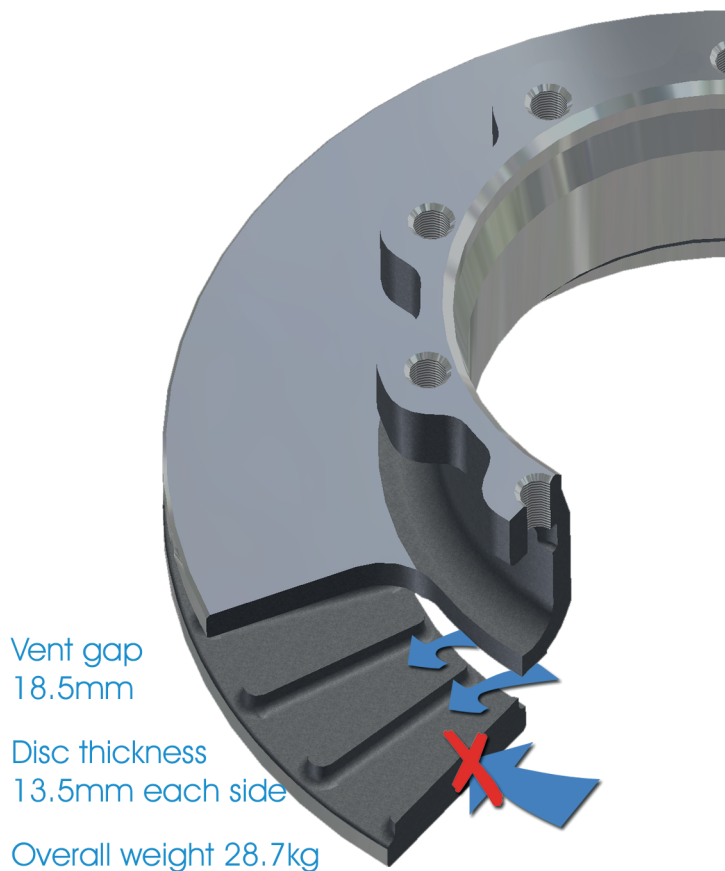

Airflow travels in one direction only, also increasing the chance of overheating.

## Fras-Le Design

### Improvement

Pillar type vents provide greater support for the braking surface, preventing high spots and thermal cracking.

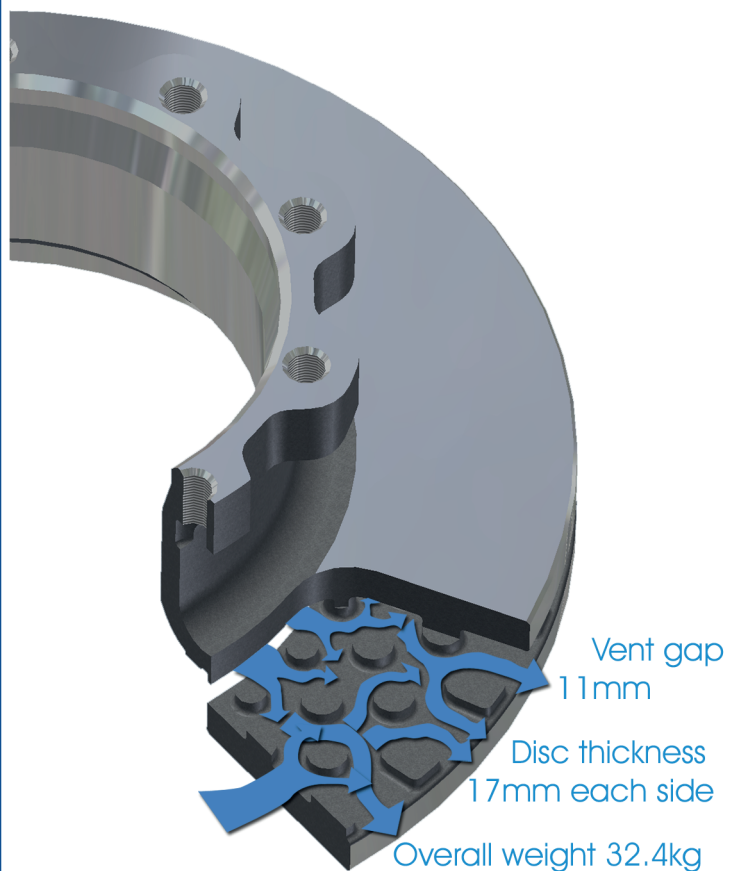

This multi-directional design increases airflow for greater cooling properties. The increased thickness of the braking surface also reduces the risk of thermal cracking.



[www.fras-le.uk](http://www.fras-le.uk)

11/2023



/frasleuk



/frasleuk



/frasleuk

